



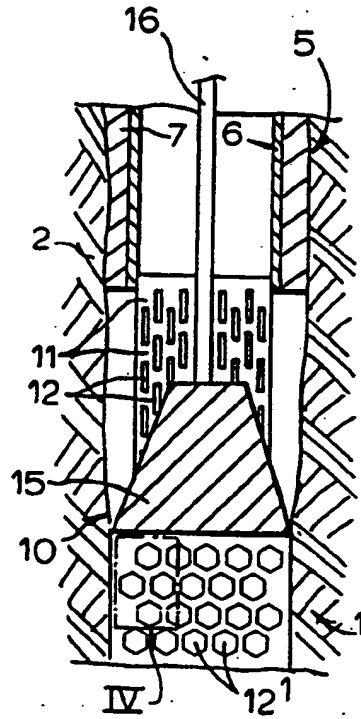
INTERNATIONAL APPLICATION PUBLISHED UNDER THE PATENT COOPERATION TREATY (PCT)

<p>(51) International Patent Classification 5 : E21B 43/10, 43/08</p>	<p>A1</p>	<p>(11) International Publication Number: WO 93/25800 (43) International Publication Date: 23 December 1993 (23.12.93)</p>
<p>(21) International Application Number: PCT/EP93/01460 (22) International Filing Date: 8 June 1993 (08.06.93) (30) Priority data: 92201669.6 9 June 1992 (09.06.92) EP (34) Countries for which the regional or international application was filed: GB et al. (71) Applicant (for CA only): SHELL CANADA LIMITED [CA/CA]; 400 - 4th Avenue S.W., Calgary, Alberta T2P 2H5 (CA). (71) Applicant (for all designated States except CA): SHELL INTERNATIONALE RESEARCH MAATSCHAPPIJ B.V. [NL/NL]; Carel van Bylandtlaan 30, NL-2596 HR The Hague (NL).</p>	<p>(72) Inventor: LOHBECK, Wilhelmus, Christianus, Maria ; Volmerlaan 6, NL-2288 GD Rijswijk (NL). (81) Designated States: AU, CA, JP, KZ, NO, NZ, RU, UA, European patent (AT, BE, CH, DE, DK, ES, FR, GB, GR, IE, IT, LU, MC, NL, PT, SE), OAPI patent (BF, BJ, CF, CG, CI, CM, GA, GN, ML, MR, NE, SN, TD, TG).  Published With international search report.</p>	

(54) Title: METHOD OF COMPLETING AN UNCASED SECTION OF A BOREHOLE

(57) Abstract

Method of completing an uncased section (10) of a borehole (1) in an underground formation (2) comprising the steps of (a) placing at a predetermined position in the borehole (1) a slotted liner (11) provided with overlapping longitudinal slots (12); (b) fixing the upper end of the slotted liner (11); and (c) moving upwardly through the slotted liner (11) an upwardly tapering expansion mandrel (15) having a largest diameter which is larger than the inner diameter of the slotted liner (11).



**FOR THE PURPOSES OF INFORMATION ONLY**

Codes used to identify States party to the PCT on the front pages of pamphlets publishing international applications under the PCT.

AT	Austria	FR	France	MR	Mauritania
AU	Australia	GA	Gabon	MW	Malawi
BB	Barbados	GB	United Kingdom	NL	Netherlands
BE	Belgium	GN	Guinea	NO	Norway
BF	Burkina Faso	GR	Greece	NZ	New Zealand
BG	Bulgaria	HU	Hungary	PL	Poland
BJ	Benin	IE	Ireland	PT	Portugal
BR	Brazil	IT	Italy	RO	Romania
CA	Canada	JP	Japan	RU	Russian Federation
CF	Central African Republic	KP	Democratic People's Republic of Korea	SD	Sudan
CC	Congo	KR	Republic of Korea	SE	Sweden
CH	Switzerland	KZ	Kazakhstan	SK	Slovak Republic
CI	Côte d'Ivoire	LI	Liechtenstein	SN	Senegal
CM	Cameroun	LK	Sri Lanka	SU	Soviet Union
CS	Czechoslovakia	LU	Luxembourg	TD	Chad
CZ	Czech Republic	MC	Monaco	TG	Togo
DE	Germany	MG	Madagascar	UA	Ukraine
DK	Denmark	ML	Mali	US	United States of America
ES	Spain	MN	Mongolia	VN	Viet Nam
FI	Finland				

## METHOD OF COMPLETING AN UNCASSED SECTION OF A BOREHOLE

The present invention relates to completing an uncased section of a borehole in an underground formation. An example of such a borehole is a borehole drilled to a hydrocarbon-containing formation in order to produce hydrocarbons from the formation.

5 To prevent collapse of the wall of the borehole, the borehole is cased by means of a casing arranged in the borehole, which casing is fixed in the borehole by a cement layer between the outer wall of the casing and the inner wall of the borehole.

10 To allow substantially unrestricted influx of fluids from the hydrocarbon-containing formation into the borehole, the borehole is not cased where it traverses the hydrocarbon-containing formation. When the hydrocarbon-containing formation is so weak that it will collapse, the uncased borehole section is completed with a liner which is provided with slots to allow fluid influx into the bore-  
15 hole.

A known method of completing an uncased section of a borehole in an underground formation comprises the steps of placing a slotted liner in the borehole at the location of the hydrocarbon-containing formation and fixing the liner. Fixing the liner is  
20 usually done by securing the upper end of the liner to the lower end of the casing arranged in the borehole.

As the inner diameter of the cased section is less than the diameter of the borehole and as the slotted liner has to be lowered through the cased section of the borehole, the diameter of the  
25 slotted liner is smaller than the diameter of the borehole, and thus there is an annular space between the liner and the wall of the borehole. With time the formation will collapse and settle against the outer wall of the liner so that the annular space gets filled with particulates. When hydrocarbons are produced, the fluid  
30 will flow through the formation, through the filled annular space

- 3 -

slotted liner having overlapping slots. This publication, however, does not disclose expanding the slotted liner.

As the slotted liner will act as a filter a slotted liner is sometimes referred to as a strainer.

5 The invention will now be described by way of example in more detail with reference to the accompanying drawings, wherein

Figure 1 shows schematically a longitudinal of a cased borehole having an uncased section that has to be completed;

10 Figure 2 shows part of Figure 1, wherein the part of the slotted liner has been expanded;

Figure 3 shows detail III of Figure 1 drawn to a scale which is larger than the scale of Figure 1;

Figure 4 shows detail IV of Figure 2 drawn to a scale which is larger than the scale of Figure 2;

15 Figure 5 shows schematically a cross-section of the slotted liner to indicate relevant dimensions; and

Figure 6 shows schematically an alternative embodiment of an expansion mandrel.

20 Reference is now made to Figure 1 showing the lower part of a borehole 1 drilled in an underground formation 2. The borehole 1 has a cased section 5, wherein the borehole 1 is lined with a casing 6 secured to the wall of the borehole 1 by means of a layer of cement 7, and an uncased section 10.

25 In the uncased section 10 of a borehole 1 a slotted liner 11 provided with overlapping longitudinal slots 12 has been lowered to a predetermined position, in this case the end of the casing 6. Please note that for the sake of clarity not all slots have been designated with a reference numeral.

30 The upper end of the slotted liner 11 has been fixed to the lower end of the casing 6 by means of a connecting means (not shown) provided with suitable seals.

35 Having fixed the upper end of the slotted liner 11 the slotted liner 11 is expanded using an expansion mandrel 15. The slotted liner 11 has been lowered at the lower end of string 16 resting on the expansion mandrel 15. To expand the slotted liner 11 the

expansion mandrel 15 is moved upwardly through the slotted liner 11 by pulling on string 16. The expansion mandrel 15 is tapered in the direction in which the mandrel 15 is moved through the slotted liner 11, in this case the expansion mandrel 15 is an upwardly tapering expansion mandrel. The expansion mandrel 15 has a largest diameter which is larger than the inner diameter of the slotted liner 11.

Figure 2 shows the slotted liner 11 in partly expanded form, wherein the lower part of the slotted liner has been expanded. The same features as shown in Figure 1 have got the same reference numerals. The deformed slots have been designated with reference numeral 12'.

Figure 3 shows the arrangement of the undeformed slots 12 in the slotted liner, 'l' is the length of the slot, 'a' is the length of the overlap, and 'b' is the width of the slot. Figure 4 shows the deformed slots 12'.

Comparing Figure 3 with Figure 4 it can be seen that the wall pieces 30 of the slotted liner wherein the slots do not overlap have deformed in circumferential direction. And in the adjacent sections wherein the slots do overlap the wall pieces 33 between adjacent slots have rotated, additionally, the wall pieces 33 have bent out of the cylindrical surface of the undeformed liner (the out of surface bending is not shown in Figure 4). The combination of rotation and bending controls the expansion, and the circumferential deformation preserves the expansion of the slotted liner.

Surprisingly it was found that for a cone angle larger than  $13^\circ$  the permanent final diameter of the slotted liner is larger than the diameter of the expansion mandrel.

Reference is now made to Figure 5, wherein ' $d_1$ ' is the original outer diameter of the slotted liner (before expansion), ' $d_c$ ' is the largest diameter of the expansion mandrel,  $\gamma$  is the cone angle, and  $d_f$  is the permanent final outer diameter of the expanded slotted liner.

With this configuration several tests have been carried out and the results are tabulated in the Table, wherein 't' is the wall

thickness of the slotted liner and 'n' is the number of slots in circumferential direction.

The results clearly show the permanent surplus expansion for a cone angle larger than 13°, for a cone angle larger than 30° the permanent surplus expansion is very pronounced.

Table. Summary of test results.

d <sub>l</sub> (mm)	t (mm)	n	l (mm)	b (mm)	a/l	γ (°)	d <sub>c</sub> (mm)	d <sub>f</sub> (mm)	
101.60	6	25	50	1.0	0.25	40	161.04	166.62	<sup>1</sup>
88.90	7	24	50	0.7	0.25	40	133.35	136.91	<sup>1</sup>
44.45	2.8	16	40	1.0	0.10	65	73.79	80.01	<sup>2</sup>
38.10	2.8	16	30	1.0	0.33	13	56.39	55.63	<sup>2</sup>
38.10	2.8	16	30	1.0	0.33	30	56.39	59.06	<sup>2</sup>
38.10	2.8	16	30	1.0	0.33	30	56.39	57.53	<sup>2</sup>
38.10	2.8	16	30	1.0	0.33	40	56.39	60.20	<sup>2</sup>
31.75	2	16	25	1.0	0.17	40	55.56	61.60	<sup>2</sup>
31.75	2	8	30	1.0	0.33	45	55.56	56.52	<sup>2</sup>
25.40	1.8	12	30	1.0	0.25	65	39.12	41.15	<sup>2</sup>
25.40	1.8	12	30	1.0	0.25	80	50.67	55.88	<sup>3</sup>
25.40	1.8	12	30	1.0	0.25	40	49.28	50.29	<sup>3</sup>
25.40	1.8	12	30	1.0	0.25	65	39.12	40.64	<sup>3</sup>

<sup>1</sup> Tube is made of J55 steel having a minimum yield strength of 380 MPa (55 000 psi) and a minimum tensile strength of 520 MPa (75 000 psi).

<sup>2</sup> Tube is made of coil tubing steel having a minimum yield strength of 480 MPa (70 000 psi) and a minimum tensile strength of 550 MPa (80 000 psi).

<sup>3</sup> Tube is made of AISI 316L steel having a minimum yield strength of 190 MPa (28 000 psi) and a minimum tensile strength of 490 MPa (71 000 psi).

Reference is now made to Figure 6, showing an alternative expansion mandrel 40 consisting of a cylindrical housing 41 having axial fingers 42 which can deflect outwardly and a cone 44 arranged with axial play in the cylindrical housing 41 to deflect the fingers 42 outwardly. To the cone 44 is connected a string 46 for moving the expansion mandrel 40 through the slotted liner (not shown).

In an alternative embodiment of the invention, a system of two or more slotted liners one arranged in the other is placed at a predetermined position in the borehole. Suitably a pair of slotted liners is employed. Each slotted liner is provided with overlapping slots and the slotted liners are arranged one in the other, wherein the relative position of the liners can be so selected that after expansion the slots are in radial direction either in line or not in line. When after expansion the slots are not in line in radial direction, fluids passing through the system have to traverse a zig-zag path; therefore this embodiment is suitable for preventing sand from entering into the borehole.

Another way of preventing sand from entering into the borehole is providing the outer surface of the slotted liner with a wrapping. Suitably the wrapping is a membrane or a screen having a fine mesh or a screen of sintered material or of sintered metal. The wrapping can as well be applied on the outer surface of the outermost slotted liner of the system of slotted liners.

In the above it was described that the slotted liner is lowered resting on the expansion mandrel; alternatively the liner is lowered first, is fixed and the expansion mandrel in contracted form is lowered through the slotted liner. After which the mandrel is expanded and pulled upwardly to expand the slotted liner.

The method according to the invention can be applied in a vertical borehole or in a deviated borehole or in a borehole having a horizontal end section.

A borehole can be drilled to allow production of fluids from an underground formation through the borehole, or the borehole can be used to inject fluids into the underground formation. The method of

the present invention can also be used to complete a section of such a latter borehole.

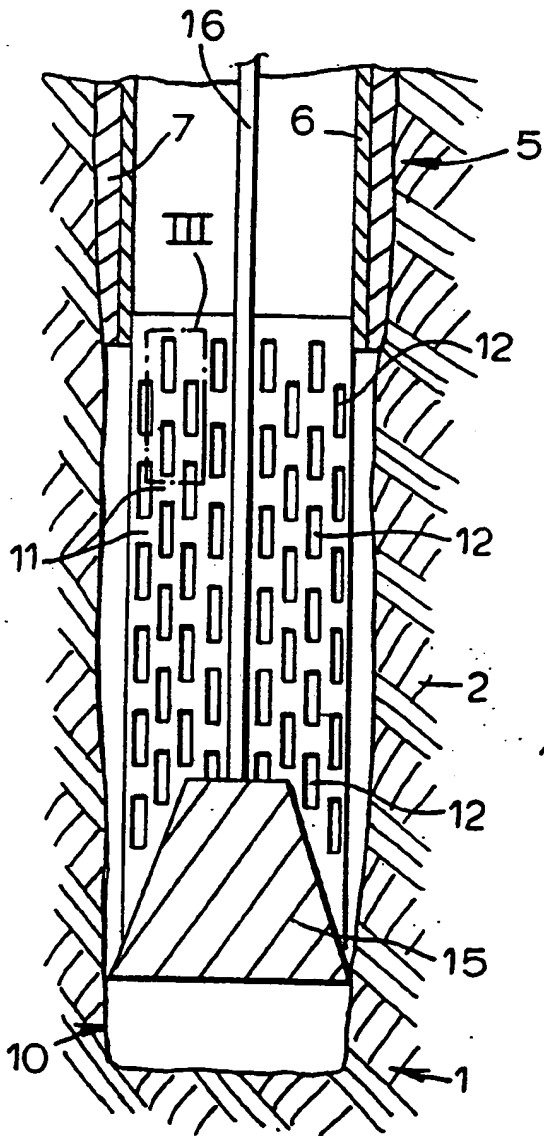
5 The geometries of the slotted liner and of the expansion mandrel can be so selected that the final diameter of the uncon-  
fined (freely) expanded slotted liner,  $d_f$  in Figure 5, is larger than the diameter of the borehole. In this case the expanded  
slotted liner is compressed against the wall of the borehole and this further increases the stability of the borehole.

10 The expansion mandrel as described with reference to the Figures has a conical shape, when the intersecting line of the outer surface and a plane through the longitudinal axis of the expansion mandrel is curved, the half cone angle is defined by the tangent of the inner wall of the slotted liner and the curved intersecting line.

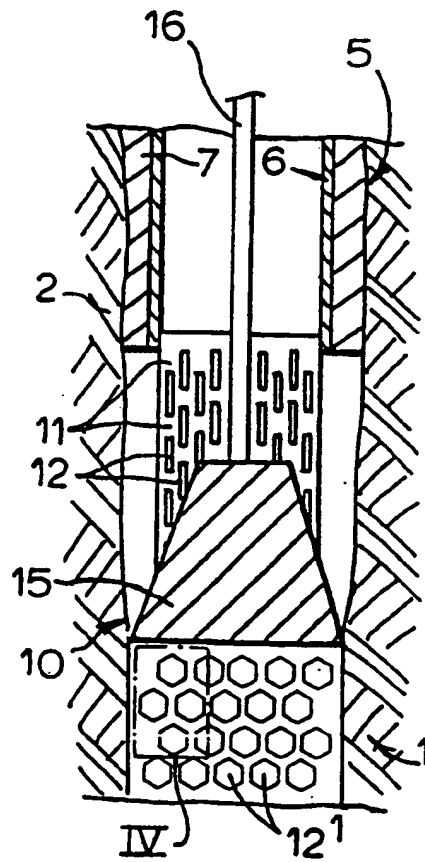


C L A I M S

1. Method of completing an uncased section of a borehole in an underground formation comprising the steps of
  - (a) placing at a predetermined position in the borehole a slotted liner provided with overlapping longitudinal slots;
  - 5 (b) fixing the slotted liner; and
  - (c) moving through the slotted liner an expansion mandrel which is tapered in the direction in which the mandrel is moved through the slotted liner, which mandrel has a largest diameter which is larger than the inner diameter of the slotted liner.
- 10 2. Method according to claim 1, wherein step (a) comprises placing at a predetermined position in the borehole a system of two or more slotted liners one arranged in the other and each slotted liner being provided with overlapping longitudinal slots.
3. Method according to claim 1, wherein the outer surface of the slotted liner is provided with a wrapping.
- 15 4. Method according to claim 2, wherein the outer surface of the outermost slotted liner is provided with a wrapping.
5. Method according to any one of the claims 1-4, wherein step (c) comprises moving through the slotted liner an expansion mandrel consisting of a cylindrical housing having outwardly deflecting fingers and a cone arranged with axial play in the cylindrical housing to deflect the fingers outwardly.
- 20

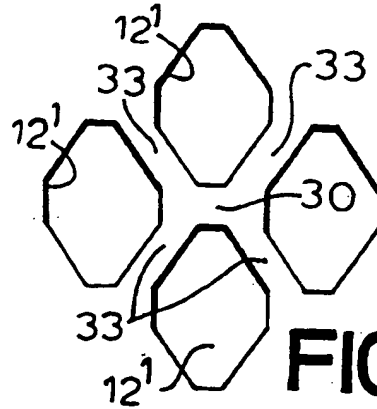
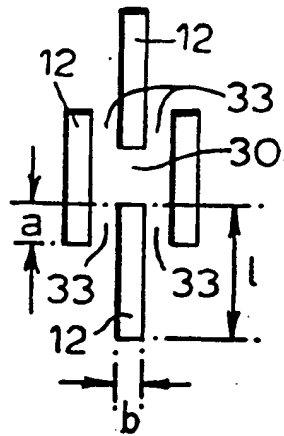


**FIG. 1**

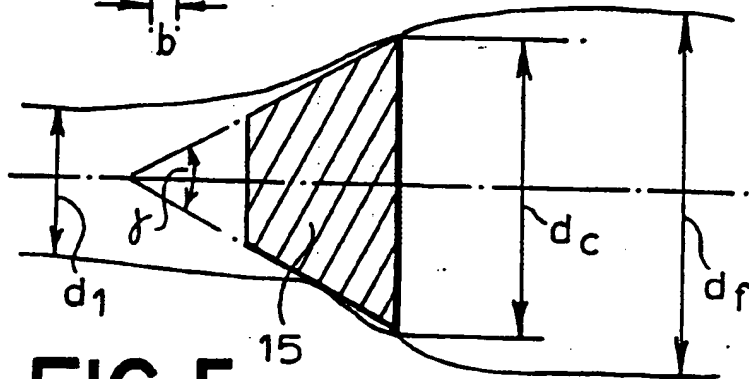


**FIG. 2**

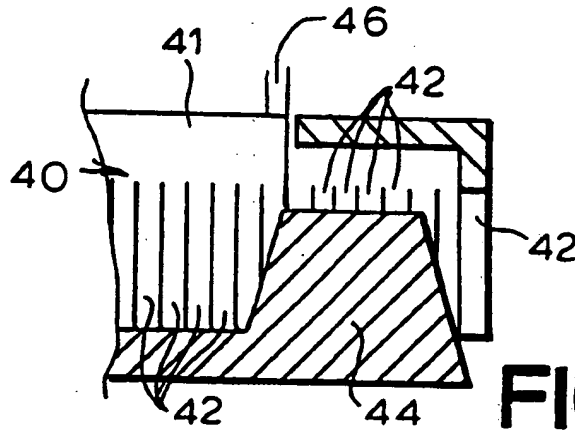
**FIG.3**



**FIG.4**



**FIG.5**



**FIG.6**

INTERNATIONAL SEARCH REPORT .

International Application No

PCT/EP 93/01460

<b>I. CLASSIFICATION OF SUBJECT MATTER</b> (if several classification symbols apply, indicate all) <sup>6</sup> According to International Patent Classification (IPC) or to both National Classification and IPC Int.Cl. 5 E21B43/10; E21B43/08		
<b>II. FIELDS SEARCHED</b> Minimum Documentation Searched <sup>7</sup>		
Classification System	Classification Symbols	
Int.Cl. 5	E21B	
Documentation Searched other than Minimum Documentation to the Extent that such Documents are Included in the Fields Searched <sup>8</sup>		
<b>III. DOCUMENTS CONSIDERED TO BE RELEVANT<sup>9</sup></b>		
Category <sup>9</sup>	Citation of Document, <sup>11</sup> with indication, where appropriate, of the relevant passages <sup>12</sup>	Relevant to Claim No. <sup>13</sup>
X	US,A,3 191 680 (VINCENT) 29 June 1965	1,3,5
Y	see column 3, line 26 - column 6, line 28; figures 1,2	2,4
Y	US,A,4 977 958 (MILLER) 18 December 1990 see column 2, line 51 - column 3, line 8; figures 1,6,10	2,4
X	US,A,3 353 599 (SWIFT) 21 November 1967	1,3
A	see column 3, line 62 - column 5, line 30; figures 3-5	4
	-/--	
<p><sup>9</sup> Special categories of cited documents: <sup>10</sup></p> <p>"A" document defining the general state of the art which is not considered to be of particular relevance</p> <p>"E" earlier document but published on or after the international filing date</p> <p>"L" document which may throw doubts on priority claim(s) or which is cited to establish the publication date of another citation or other special reason (as specified)</p> <p>"O" document referring to an oral disclosure, use, exhibition or other means</p> <p>"P" document published prior to the international filing date but later than the priority date claimed</p> <p>"T" later document published after the international filing date or priority date and not in conflict with the application but cited to understand the principle or theory underlying the invention</p> <p>"X" document of particular relevance; the claimed invention cannot be considered novel or cannot be considered to involve an inventive step</p> <p>"Y" document of particular relevance; the claimed invention cannot be considered to involve an inventive step when the document is combined with one or more other such documents, such combination being obvious to a person skilled in the art.</p> <p>"A" document member of the same patent family</p>		
<b>IV. CERTIFICATION</b>		
Date of the Actual Completion of the International Search		Date of Mailing of this International Search Report
06 AUGUST 1993		27. 08. 93
International Searching Authority		Signature of Authorized Officer
EUROPEAN PATENT OFFICE		LINGUA D.G.

III. DOCUMENTS CONSIDERED TO BE RELEVANT (CONTINUED FROM THE SECOND SHEET)		
Category *	Citation of Document, with indications, where appropriate, of the relevant passages	Relevant to Claim No.
X	US,A,3 498 376 (SIZER ET AL.) 3 March 1970	1
A	see column 3, line 56 - column 4, line 38; figures 1A-1C	5
A	--- US,A,2 383 214 (PROUT) 21 August 1945 see page 1, left column, line 50 - page 2, left column, line 17; figures -----	1,5

**ANNEX TO THE INTERNATIONAL SEARCH REPORT  
ON INTERNATIONAL PATENT APPLICATION NO.**

EP 9301460  
SA 75041

This annex lists the patent family members relating to the patent documents cited in the above-mentioned international search report.  
The members are as contained in the European Patent Office EDP file on

The European Patent Office is in no way liable for those particulars which are merely given for the purpose of information. 06/08/93

Patent document cited in search report	Publication date	Patent family member(s)	Publication date
US-A-3191680		None	
US-A-4977958	18-12-90	CA-A- 1319098	15-06-93
US-A-3353599		None	
US-A-3498376	03-03-70	None	
US-A-2383214		None	

EPO FORM P047

For more details about this annex : see Official Journal of the European Patent Office, No. 12/82